

# Technical Manual for the RTCU MX2i pro/pro+

Version 2.10



## Introduction

This manual contains technical documentation allowing easy installation and use of the RTCU MX2i pro/pro+ unit. For information on the programming and software configuration of the RTCU MX2i pro/pro+ please refer to the RTCU IDE documentation.

The RTCU MX2i pro/pro+ is the most powerful variants in the versatile MX2i family, and includes a list of advanced features only available on these State of The Art products. The RTCU MX2i pro/pro+ has dramatically improved GPS performance with the 66-channels ultra high-sensitivity SuperGPS receiver opening up for deep urban or even indoor tracking applications. The RTCU MX2i pro+ adds additionally 8 MByte of dataflash supporting the most data intensive applications.

The product is especially suited for mobile tracking applications with its on-board GPS-receiver and advanced power-management features. The unit is fully supported by the RTCU IDE development tool and is fully back-ward compatible with previous generation of RTCU units.

The RTCU MX2i pro/pro+ includes many sophisticated features, including a CAN-bus interface for connection to vehicle bus networks, 512 KByte internal flash drive and SD-CARD reader with a FAT compatible file-system for easy sharing of files with a PC. There is optional support for Bluetooth, Ethernet, Wi-Fi, Camera module and a Mobile Data Terminal.

As a unique feature the RTCU MX2i pro/pro+ fully supports the Garmin Fleet Management / Navigation Interface allowing development of advanced navigation / messaging applications.

The advanced power-management features on the RTCU MX2i pro/pro+ combined with the on-board high-capacity Li-Ion battery allows the unit to stay in power-saving mode for a longer period of time still being connected to the GSM network and capable of waking up on for example GSM activity, change of digital inputs or a vibration sensor!

These features open up for the use of the RTCU MX2i pro/pro+ in exciting new application areas where extremely low power consumption and flexible wake-up conditions are a crucial parameter for successful product integration.

The RTCU MX2i pro+ has the same feature set as the RTCU MX2i pro, except for the extended 8 MByte of dataflash, and references made to the RTCU MX2i pro throughout this document also include the RTCU MX2i pro+.

## Table of Contents

Introduction .....	2
Table of Contents .....	3
Graphical view.....	4
External connections .....	5
Overview .....	5
Power supply .....	8
Digital Outputs .....	9
Digital Inputs / Ignition Input .....	10
Analog Inputs.....	11
Serial port 1 / programming port. ....	11
RS485 (optional).....	12
Serial port 2 .....	13
CAN.....	14
1-Wire .....	15
DC-Out .....	15
Headset connector .....	16
Vibration Sensor.....	16
Indicators (LED's).....	17
Switches.....	18
DIP-Switch.....	18
System switch (RST) .....	18
Internal Li-Ion battery .....	19
Installing the SIM-card .....	20
Installing the SD-CARD.....	21
Antennas .....	22
GSM .....	22
GPS.....	22
Barcode.....	22
Power consumption.....	23
Specifications for the RTCU MX2i pro / pro+ .....	24
Specifications for the 66-channels SuperGPS receiver.....	25
Appendix A – Enabling the CAN bus Write capability .....	26

## Graphical view



## External connections

### Overview

Connections to external equipment are done via the connectors located back and forth on the product. All connections are available externally for easy access; this also includes SIM-Card and SD-Card. There are no user-serviceable parts inside and the warranty is void if the unit is disassembled.

The front plate is equipped with connectors commonly accessed by the user; SIM-Card, SD-CARD, DIP-Switch, Headset, LED's and RS232. The back plate holds all connectors necessary for installation; 4-pin for Power and ignition, 6-pin for RS232/Programming, 12-pin for different communication interfaces and a 16-pin for digital I/O + analog inputs. Connection to Quad-band GSM antenna is via a SMA female and connection to a 3V active GPS antenna is done via the SMB male connector. Both antenna connectors are located on the back plate. A graphical overview of the front- and back plate is shown below:

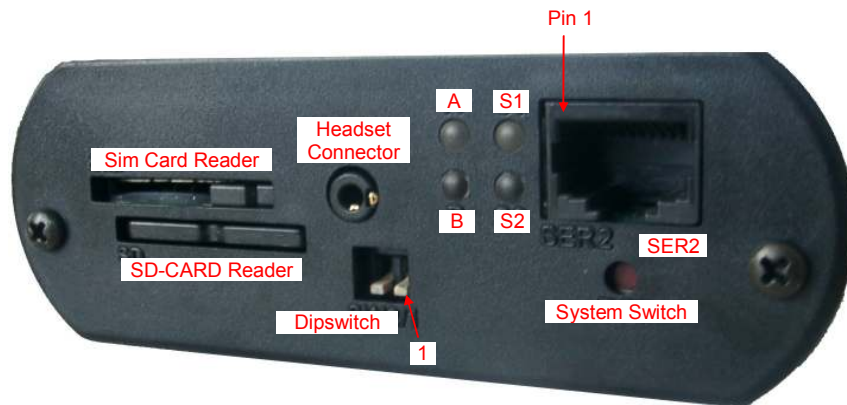

Front-side view

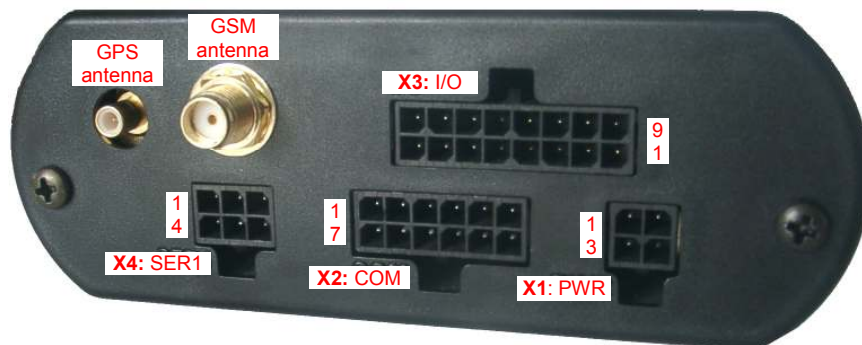

Back-side view

**Connector X1: 4 pin PWR connector overview.**

Pin	Name	Description
1	SUPP	Power supply, positive (+) connection
2	DI5/IGN	Digital input 5 / Ignition input (Shared with 16 pin connector)
3	SUPP	Power supply, positive (+) connection
4	PGND	Power Ground

**Connector X2: 12 pin COM connector overview.**

Pin	Name	Description
1	1Wire	1-Wire bus for ID-Button / Temperature sensor
2	SGND	Signal Ground
3	CAN-H	CAN-bus H-signal
4	Voice	External voice
5	RS485+	RS485 non-inverting signal
6	RS485-	RS485 inverting signal
7	1W-LED	1-Wire ID-Button LED
8	SGND	Signal Ground
9	CAN-L	CAN-bus L-signal
10	SGND	Signal Ground
11	SGND	Signal Ground
12	DC-Out	+3.3V/150mA DC-Out for external equipment. (Shared with 6 pin connector)

**Connector X3: 16 pin I/O connector overview.**

Pin	Name	Description
1	DOUT 1	Digital output 1
2	DOUT 3	Digital output 3
3	DIN 1	Digital input 1
4	SGND	Signal Ground
5	DIN 3	Digital input 3
6	DIN 5/IGN	Digital input 5 / Ignition input (Shared with 4 pin connector)
7	AIN 1	Analog input 1
8	AIN 2	Analog input 2
9	DOUT 2	Digital output 2
10	DOUT 4	Digital output 4
11	DIN 2	Digital input 2
12	SGND	Signal Ground
13	DIN 4	Digital input 4
14	SGND	Signal Ground
15	AGND	Analog Ground
16	AGND	Analog Ground

**Connector X4: 6 pin SER1 connector overview.**

Pin	Name	Description
1	TD	Transmit Data from serial port 1, RS232 compatible
2	RS-DET	Programming cable detect, normally unconnected (if programming cable, connect to GND)
3	DC-Out	+3.3V/150mA DC-Out for external equipment. (Shared with 12 pin connector)
4	RD	Receive Data for serial port 1, RS232 compatible
5	SGND	Signal Ground
6	SGND	Signal Ground

**Connector SER2: RJ45 connector overview, fully RS232 compatible.**

Pin	Name	Description
1	DSR	Data Set Ready
2	DCD	Data Carrier Detect
3	DTR	Data Terminal Ready
4	SGND	Signal Ground
5	RD	Receive Data for serial port 2
6	TD	Transmit Data from serial port 2
7	CTS	Clear To Send
8	RTS	Request To Send

**Accessories available from Logic IO for cable assembly.**

Order-code	Name
RT-O-TYCO-H4 TYCO p/n: 794617-4	Tyco, Connector house 4 pins. Bag with 10 pcs
RT-O-TYCO-H6 TYCO p/n: 794617-6	Tyco, Connector house 6 pins. Bag with 10 pcs
RT-O-TYCO-H12 TYCO p/n: 1-794617-2	Tyco, Connector house 12 pins. Bag with 10 pcs
RT-O-TYCO-H16 TYCO p/n: 1-794617-6	Tyco, Connector house 16 pins. Bag with 10 pcs
RT-O-TYCO-CR TYCO p/n: 794606-1	Tyco, Crimp Contacts for connector house. Wire size 0.2 to 0.5 mm <sup>2</sup> . Bag with 100 pcs.
RT-O-TYCO-TOOL TYCO p/n: 91501-1	Tyco, Crimp hand tool for easy assembly of TYCO crimp contacts. Wire size 0.2 to 0.5 mm <sup>2</sup>
Recommended tool:	Tyco 91501-1 (0.20 to 0.50mm <sup>2</sup> ) RS 495-9675, Farnell 1111475
Alternative tools:	Tyco 91502-1 (0.05 to 0.15mm <sup>2</sup> ) RS 495-9675, Farnell 1111476 Molex 69008-0982 (0.20 to 0.50mm <sup>2</sup> ) RS 233-3059, Farnell 673122 Molex 69008-0983 (0.05 to 0.05mm <sup>2</sup> ) RS 233-3065, Farnell 673134
Extraction tool:	Tyco 843996-6 extraction tool. RS 495-9704, Farnell 1111477
2.5mm MicroJack	Plug for headset connector. Farnell 5096339 (black plastic house) or Farnell 8045453 (metal house).

**Power supply**

The RTCU MX2i pro unit is to be supplied with 8..36 VDC from an external DC power source connected to the 4 pin power connector. Positive power is applied to the SUPP pin and ground is connected to the PGND pin.

The connector has two “SUPP” supply pins as these also supplies power for the Digital Outputs. If the total current consumption on the digital outputs exceeds 1.5A then power must be applied to both pins. Otherwise one pin would be sufficient.

There are three different labels for the ground connections: Power Ground (PGND), Signal Ground (SGND) and Analog Ground (AGND). The signal and analog grounds are filtered from the power ground. Power ground must only be used as power supply return path. The signal ground is used as ground reference for digital I/O’s and serial interfaces. And the analog ground is used as a low noise analog ground reference for the analog inputs.

The RTCU MX2i pro is protected against wrong polarity. If a chassis or system grounds are connected to either SGND or AGND a wrong polarity on the supply lines will destroy the internal GND connection. For avoidance of such a scenario a fuse can be installed on the positive supply.

The RTCU also contains an internal high capacity backup battery, which will supply the RTCU if the external power supply should fail or be disconnected. By default the RTCU is powered down when a power fail occur. This setting however can be changed. Please consult the RTCU-IDE online help for more information.

When the ignition input is activated with a logical high, the RTCU unit will wake-up if it was in power down mode. The ignition input (digital input 5) is available on the power connector to minimize the need for connectors in minimal connector installations, but it is also available on the 16 pin connector (digital I/O and analog Inputs) - only one should be used at a time.

**Please Note:**

- In-rush currents up to 2A can occur on initial power apply.

**X1: 4 pin PWR connector overview.**

Pin	Name	Description
1	SUPP	Power supply, positive (+) connection
2	DI5/IGN	Digital input 5 / Ignition input (Shared with 16 pin connector)
3	SUPP	Power supply, positive (+) connection
4	PGND	Power Ground

## Digital Outputs

The digital outputs control four “high-side” switches. They function like a contact, where one side is connected to the positive supply of the RTCU unit, and the other is the output. The switches are protected against short circuit, ESD and electronic kickback from inductive loads such as relays etc. The maximum switch-able inductance is 20mH and must not be exceeded.

The digital outputs are supplied through the 4 pin power connector, which also supplies the rest of the RTCU unit. As the power is also the RTCU MX2i pro main power, a power-fail would also affect the digital outputs.

The RTCU unit offers a very advanced power management, which makes it possible to have one or more outputs enabled while the RTCU is in low power mode. Please consult the RTCU-IDE online help for more information.

**Please note:** Special attention to wiring must be taken; if the total current consumption of the digital outputs exceeds 1.5A then PGND must be used as return path for the output(s). If the total current consumption of the digital outputs exceeds 5A the two SUPP pins and PGND must be used for supply.

### X3: 16 pin I/O connector overview.

Pin	Name	Description
1	DOUT 1	Digital output 1
9	DOUT 2	Digital output 2
2	DOUT 3	Digital output 3
10	DOUT 4	Digital output 4

### Digital Inputs / Ignition Input

The digital inputs are all low-pass filtered and transient protected. To activate the inputs, connect a positive voltage between the input and the GND connector.

**Please note:** The DIN 5/IGN input is a special input as it also functions as the ignition input. If the ignition input is activated with a logical high or low (Wait For Event mode only) when the RTCU is in low power mode, it will wake-up the unit. A power apply will also wake-up the unit if it is in power-down mode or WaitForEvent mode with power Apply and/or ignition selected for wake-up. The ignition is de-bounced with a period between 1-2 ms when used as a digital input. So any logical level applied to this input must be greater than 2 ms to be valid. The DIN 5/IGN input is available on both the 4 pin power connector and the 16 pin connector together with the other digital inputs – only one should be used at a time.

The power management allows the possibility to configure a wake-up on one or more digital inputs with individually configured falling- or rising edge detection. Please consult the RTCU-IDE online help for more information.

#### X3: 16 pin I/O connector overview.

Pin	Name	Description
3	DIN 1	Digital input 1
11	DIN 2	Digital input 2
5	DIN 3	Digital input 3
13	DIN 4	Digital input 4
6	DIN 5/IGN	Digital input 5 / Ignition input. (Shared with 4 pin connector)
4	SGND	Signal Ground
10	SGND	Signal Ground
14	SGND	Signal Ground

### Analog Inputs

The analog inputs are voltage inputs with a range from 0V to 10V DC. The analog voltage is converted to a digital value with a resolution of 10bit or 1024 in decimal. The decimal value with 10V applied to the input is 1023 and 512 for 5V.

The input signal is connected between AINx and AGND. AGND must be connected to the reference of the connected equipment. Please be aware that deviations may occur, as the system is very noise sensitive. Avoid long unshielded wires and large fast-changing signals routed parallel to the analog signals.

The inputs are low-pass filtered, ESD- and transient protected.

#### X3: 16 pin I/O connector overview.

Pin	Name	Description
7	AIN 1	Analog input 1
8	AIN 2	Analog input 2
15	AGND	Analog Ground
16	AGND	Analog Ground

#### Serial port 1 / programming port.

This port can be used as general-purpose RS232 serial port or as a programming port. In order to use the port for programming, the RS-DET pin must be connected to GND. When using the port as general-purpose RS232, the RS-DET pin must be left unconnected. Further details on the programming cable are available in the RTCU-IDE online help.

#### X4: 6 pin SER1 connector overview.

Pin	Name	Description
1	TD	Transmit Data from serial port 1, RS232 compatible
4	RD	Receive Data for serial port 1, RS232 compatible
2	RS-DET	Programming cable detect, normally unconnected (if programming cable, connect to GND)
5	SGND	Signal Ground

**RS485 (optional)**

If RS485 option is installed and enabled, RS485 will be available on the COM connector (12 pin). Internally RS485 and the programming port (SER1) share the same signals and RS485 will be disabled if a programming cable is inserted or RS-DET is low.

The RS485 is a multi-drop network with a maximum of 32 units connected simultaneously to the bus. The RS485 bus contains a RS485+ (non-inverting) and a RS485- (inverting) signal, as well as a signal ground, which must always be connected to the common signal ground for all units connected to the RS485 bus!

The maximum cable length for the RS485 bus is according to EIA/TIA-485-A standard (max. 1200m @ <100kbit); this limit is highly influenced by the quality of the cable, signaling rate, noise etc. At longer cable lengths, noisy environments or high communication speed it might be necessary to terminate the transmission line with a 120<sup>1</sup> ohm resistor between terminal RS485+ and terminal RS485- at each end of the wires to avoid signal reflections etc.

**X2: 12 pin COM connector overview.**

Pin	Name	Description
5	RS485+	RS485 non-inverting signal (A)
6	RS485-	RS485 inverting signal (B)
11	SGND	Signal Ground

<sup>1</sup> Assuming use of a CAT5 twisted pair cable

## Serial port 2

The serial port 2 is a general-purpose RS232 port with all control signals according to EIA-561 that defines RS232 on a modular connector.

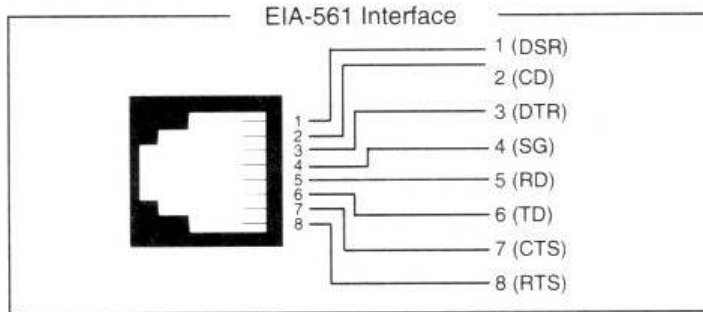

The signals are available on the RJ-45 connector located on the front plate of the RTCU.

### Connector SER2: RJ-45 connector overview, fully RS232 compatible.

Pin	Name	Description
1	DSR	Data Set Ready
2	DCD	Data Carrier Detect
3	DTR	Data Terminal Ready
4	SGND	Signal Ground
5	RD	Receive Data for serial port 2
6	TD	Transmit Data from serial port 2
7	CTS	Clear To Send
8	RTS	Request To Send

## CAN

The RTCU MX2i pro provides the physical layer for the CAN (Controller Area Network) serial communication interface in accordance with the ISO 11898 standard. The CAN bus is designed for high-speed (up to 1Mbit) robust communication in especially harsh environments like those found in the automotive industry.

The CAN interface can either be connected to an existing CAN network with a common protocol like the J1939 standard to retrieve information for surveillance or information purposes. Or the interface can be used as a robust serial data link with a non-standard protocol. Please consult the RTCU-IDE online help for more information.

The physical layer consists of a two wire (CAN-H and CAN-L) differential bus and a signal ground for reference.

If the RTCU is connected to a “non-existing” network, a 120<sup>2</sup> ohm resistor must be connected between CAN-H and CAN-L at each end of the transmission-line to terminate it and avoid signal reflections.

Be aware that connecting the RTCU to a CAN network can be dangerous. If the RTCU is not configured with the correct network parameters, it will lead to network corruption and may interfere with other connected equipment on the bus. Especially in vehicles great precautions must be observed to prevent interruption of the communication.

By default only Reading from the CAN bus is enabled and the Write capability is disabled by a hardware jumper inside the unit. Removing this jumper is done on the sole responsibility of the user and Logic IO can not be held responsible for any problems or damage due to this decision. For information how to enable CAN Write capability please refer to Appendix A.

A wide range of software functions is available for easy access to the network. Please consult the RTCU IDE online help for further information.

### X2: 12 pin COM connector overview.

Pin	Name	Description
3	CAN-H	CAN-bus H-signal
9	CAN-L	CAN-bus L-signal
8	SGND	Signal Ground

<sup>2</sup> Assuming use of a CAT5 twisted pair cable

### 1-Wire

The 1-Wire bus is available on the 12 pin connector. All 1-Wire communication goes through this single pin and all 1-Wire devices connected to this pin retrieves its power directly from the bus (called parasitic power). By this only two wires are needed – the 1-wire signal and the ground reference – allowing minimal cable installations.

For 1-Wire ID-Button readers, which include a built-in LED, a dedicated output is available for this purpose. Please consult the RTCU-IDE online help for further information.

Further information regarding 1-wire networks, topology and limitations can be found in the application note area on the Logic IO webpage.

#### X2: 12 pin COM connector overview.

Pin	Name	Description
1	1Wire	1-Wire bus for ID-Button / Temperature sensor
7	1W-LED	1-Wire ID-Button LED
2	SGND	Signal Ground

### DC-Out

A 3.3V DC output is available on the 12 pin connector. It is possible to control the output in order to save power. The output is short circuit- (to ground), ESD- and transient protected. The output is also available on the 6 pin serial port 1 connector. Make sure not exceed the current specification of the output and be aware of inrush currents of the external equipment may exceed the specifications. It is recommended to install a fuse to protect the output.

This output must be enabled from the application. Please consult the RTCU-IDE online manual for more information.

#### X2: 12 pin COM connector overview.

Pin	Name	Description
12	DC-Out	+3.3V/150mA DC-Out for external equipment. (Shared with 6 pin connector)
11	SGND	Signal Ground

### Headset connector

The RTCU unit has a 4-pole 2.5mm jack connector for connecting a Nokia compatible headset to the built-in GSM modem. The speaker output is amplified through the internal amplifier and is a differential (balanced) signal. An audio line transformer must be used to convert the signal to a single ended signal, when connected to external equipment that does not have a differential (balanced) input. Otherwise the GSM noise will not be suppressed / cancelled, and will pass through all the way to the loudspeaker. An external amplifier should be used when connecting a loudspeaker.

The microphone signal is biased internal for active microphones.



#### 4 pin headset connector overview.

Pin	Name	Description
1	Mic +	Microphone positive Input
2	SPK +	Speaker positive output
3	Mic -	Microphone negative input
4	SPK -	Speaker negative output

Please consult the RTCU-IDE online manual for more information about enabling this feature.

### Vibration Sensor

The RTCU MX2i pro unit contains a vibration sensor. It makes it possible through the power management to detect vibrations when for example the vehicle is moved. The sensitivity can be altered from within the VPL program - making it suitable for various applications. Please consult the RTCU-IDE online manual for more information.

## Indicators (LED's)

Three bi-colored (red and green) and a single yellow LED indicators are present on the front of the unit (see the graphical view). Two bi-colored LED's (A and B) are available to the user and the remaining two LED's (S1 and S2) are signaling the status and possible errors of the RTCU unit.

The user control LED one through four for application specific signaling purposes.

- LED named A on the front-plate, consists of LED 1 (green) and LED 2 (red)
- LED named B on the front-plate, consists of LED 3 (green) and LED 4 (red)

They are easily accessed from within the VPL program, and it is possible to mix the LED's to obtain a third color, yellow. Please consult the RTCU-IDE online manual for more information.

The remaining two LED's are used by the RTCU to signal the status of the unit. The different patterns are listed in the table below. If the color of the system LED 1+2 is yellow, the unit is actively communicating with for example the RTCU-IDE program (or another program, supporting the RTCU protocol, RACP).

### S1: System LED1 pattern overview.

Pattern	Description
Fastest blinking, green	The unit is initializing, preparing to start the VPL program
Fast blinking, green (or yellow)	The VPL program is not executing, but stopped by the reset/diagnostic switch.
500ms On / 500ms Off green (or yellow)	The unit is executing the VPL program
1.5s On / 0.5s Off. green (or yellow)	The unit is executing the VPL program and charging the internal back-up battery.
Fast blinking, red (or yellow)	A runtime error has been detected in the program. Use the RTCU IDE to obtain the fault log.
Alternating Fast/Slow, red (or yellow)	The unit has lost its Firmware! This can only happen if, during a firmware upgrade, the RTCU Unit loses power, or the communication is lost completely. In this case, simply upload the firmware to the unit again.
75ms On / 925ms Off	Execution speed is different from full-speed.

The single yellow LED is signaling either the GSM module activity or if all other LED's are off it will signal that the RTCU is in the "wait for event" low power state. Please see the table below:

**S2: System LED2 pattern overview (GSM activity and “Wait For Event”)**

Pattern	Operating Status
Off	The GSM module is turned off
600 ms On / 600 ms Off	No SIM card inserted or no PIN code entered, or network search in progress, or ongoing user authentication, or network logon in progress.
75 ms On / 3 s Off	Logged to the network. No call in progress.
75 ms On / 75 ms Off / 75 ms On / 3 s OFF	A GPRS session is active
Flashing	Indicates GPRS data transfer.
On	Depending on type of call: <i>Voice call:</i> Connected to remote party. <i>Data call:</i> Connected to remote party or exchange of parameters while setting up or disconnecting a call.
8 s OFF / 10 ms ON	The RTCU unit is in “Wait For Event” low power state.

**Switches**

**DIP-Switch**

The RTCU MX2i pro unit contains a dipswitch with two switches. The dipswitch is located on the front plate for easy user access (see the graphical view). To use the dipswitch in the RTCU-IDE declare a Boolean input variable, and define it as a dipswitch in the RTCU-IDE Job variable configuration dialog.

**System switch (RST)**

The RTCU MX2i pro unit contains a combined reset/diagnostic switch. This switch is located on the front-plate of the RTCU unit (see the graphical view).

By activating the switch shortly the RTCU unit will do a complete reset, as if the power was removed and reapplied. If the reset switch is held down for approx. 3 seconds<sup>3</sup> the VPL program/project uploaded to the unit will not be started and the unit will turn on the GSM module and establish connection to the GSM network and to GPRS / Gateway (if configured). This method will also activate the unit if it is powered down due to a power fail. The feature is very helpful when maintenance without power is needed. To “exit” (power down the unit again) from this mode simply activate the reset switch shortly. The status indicator indicates the state by fast blinking green or yellow as stated above.

<sup>3</sup> System LED S2 will flash three times when this state is entered.

### **Internal Li-Ion battery**

The RTCU MX2i pro contains an internal Li-Ion battery for operation even during an external power fail. Making it possible to report power losses etc. Please note that when external power is removed the unit will by default be powered down. This setting can be changed though and is documented in the RTCU-IDE online manual. The digital outputs are also disabled when a power fail occurs, due to that the power supplies both the digital outputs and RTCU unit itself.

The battery charging is completely automated and handled internally by the RTCU unit – leaving no need for user interaction. Different kinds of functions (Battery Low, Charger Enable, Charging status etc) are available for the user though. Please consult the RTCU-IDE online manual for more information.

The charge current is very high, for shorter charge time, as specified in the technical specifications; Make sure both power supply and cables can handle the high current.

The battery will be charged whenever a power fail has occurred to establish the capacity making the battery ready for the next power fail. A maintenance charge will start every 100-hour after the last charge. This is to compensate for the battery self-discharge etc. As standard the battery cannot be charged above 45°C or below 0°C. The RTCU unit will automatically detect the temperature and terminate the charge process if the temperature is out of this range.

Low temperature charging is available as an option. Please consult Logic IO for further information.

The temperature has very high influence on the battery capacity. At 0°C the capacity has dropped to 60% of the initial capacity and it falls dramatically at lower temperatures. The battery cycle (numbers of charges and discharges) has also influence on the capacity. After 300 cycles the capacity has dropped to approximately 80% of the initial capacity.

#### **Warning:**

Misusing the RTCU MX2i pro unit may cause the built-in battery security circuit to be damaged.

- Do not place the RTCU unit in high temperature locations such as direct sunlight or near engines. Using the RTCU unit in this environment may result in loss of battery performance and a shortened life expectancy.
- Do not expose the unit to water, salt water or allow the battery to get wet.
- Avoid strong impacts and shocks.

For more information regarding the environmental limitations see “Specifications for RTCU MX2i pro” below or consult the RTCU MX2i pro Datasheet.

## Installing the SIM-card

The RTCU MX2i pro unit contains a standard SIM card reader. It is located on the front plate (please see the graphical view) and is easily accessed. The SIM card reader has a push/push eject system and a mechanical lock for secure installation of the SIM card. Orientate the card as showed below, and insert it into the card reader. Push the card into the reader until a click sound occurs – the card will now stay in its position. It might be necessary to use a small tool or pencil as the card, for protection purposes, is placed underneath the front-plate surface. Furthermore a mechanical lock can be slide in front of the card to prevent it from being removed accidentally.

To remove the card slide the lock to its unlocked position, and push the card into the reader until a small click sound occurs. The reader will now eject the card. It might be necessary to use a small tool or pencil to push the card into the reader.

It is possible to detect the state of both the SIM Insert and SIM lock status from the VPL program. Please consult the RTCU-IDE online manual for more information.



**SIM card Orientation.**

If the SIM-card is removed during GSM operation the unit will shortly after be rejected from the GSM network. When a SIM-card is inserted again the unit will automatically reset approx. 10 seconds after insertion and then commence normal operation.

## Installing the SD-CARD

The RTCU MX2i pro unit has a standard SD-CARD reader with FAT file-system support for standard PC-compatibility. Up to 2 GByte capacity is supported. The SD-CARD features a Push/Push eject system for reliable insertion and operation.

To insert a card into the reader orientate it as showed below, and push the card into the reader until a click sound occurs. Remove the card by pushing it into the reader until it clicks and the reader will eject the card. Both the card detect and the write protect information is available to the user through VPL. Please consult the RTCU-IDE online help for more information. Avoid removing the SD-CARD during access to the card.



**SD-Card orientation**

## Antennas

### GSM

The RTCU MX2i pro unit contains an SMA Female connector for connection of a suitable GSM quad band antenna (850/900/1800/1900 MHz). When installing the antenna, please make sure that the antenna is not in close proximity of metallic parts or anything else that can influence the efficiency of the GSM antenna. Please consult the installation guide that follows the GSM antenna.

### GPS

The RTCU MX2i pro unit contains an SMB Male connector for connection of a suitable GPS antenna. The GPS antenna must be a 3V active GPS antenna mounted with a SMB Female connector.

When installing the antenna, please make sure that the antenna has a reasonable view of the sky so that it can receive the weak signals from the satellites. Please also consult the installation guide that follows the GPS antenna.

## Barcode

The barcode found on the MX2i pro/pro+ unit contains the serial number. Two formats are currently in use:

- **Long format with a total length of 17 digits.**  
The first eight digits in the barcode is Logic IO specific, and the remaining 9 digits contain the actual serial-number.
- **Short format with a total length of 9 digits.**  
The 9 digits of the barcode are equal to the unit serial-number.  
The serial-number of a unit with the short-format always starts with 2.

In 2010 the Long format is being phased out in favor of the Short format. The first three digits in the short format serial-number identify the unit type, and for the RTCU MX2 pro this unique code is **204**, **214** or **218**, and for the RTCU MX2i pro+ the code is **205**, **215** or **219**.

**The barcode format used:** 2/5 Interleaved with Check Digit

## Power consumption

Detailed information on the maximum power consumption of the MX2i unit in different states and at different supply voltages is listed below.

### Maximum power consumption: Unit running on external supply.

	8V	12V	36V		
Unit Active	75	45	20	mA	
Unit Active with GSM On	95	55	25	mA	GSM idle @ -63dBm
Unit active with GPS On	100	60	25	mA	
Unit Active with GSM/GPS On	120	70	35	mA	GSM idle @ -63dBm
Unit Active while charging	950	650	300	mA	
Unit in power-down	0.5	0.4	0.3	mA	Restart on DI5, RTC
Unit in "wait for event"	0.6	0.4	0.2	mA	Resume on DI, Vibration, RTC
Unit in "wait for event"	20	10	5	mA	Resume on CAN
Unit in "wait for event"	12	8	4	mA	Resume on RS232
Unit in "wait for event"	25	15	6	mA	Resume on GSM activity



If the external power source is removed and the internal battery is enabled the power consumption from the battery will be as listed below.

### Maximum power consumption: Unit running on internal battery.

	BAT		
Unit Active	100	mA	
Unit Active with GSM On	140	mA	GSM idle @ -63dBm
Unit active with GPS On	140	mA	
Unit Active with GSM/GPS On	180	mA	GSM idle @ -63dBm
Unit in power-down	0.8	mA	Restart on DI5, RTC
Unit in "wait for event"	1	mA	Resume on DI, Vibration, RTC
Unit in "wait for event"	25	mA	Resume on CAN
Unit in "wait for event"	15	mA	Resume on RS232
Unit in "wait for event"	25	mA	Resume on GSM activity

**Note:** Power consumption from a fully charged battery.

## Specifications for the RTCU MX2i pro / pro+

Power supply	Min	Typ	Max		
Operating Voltage	8	-	36	VDC	Protected against wrong polarity.
On-board Li-Ion Battery Pack		1.8	2	Ah	
Unit Active		45		mA	
Unit Active with GSM On		55		mA	GSM idle @ -63 dBm
Unit Active with GPS On		60		mA	
Unit Active with GSM/GPS On		70		mA	GSM idle @ -63 dBm
Unit Active while Charging		650		mA	
Unit in Power-down		0.4		mA	Restart on: DI 5 and RTC
Unit in "Wait for Event"		0.4		mA	Resume on: DI, Vibration, RTC
Unit in "Wait for Event"		10		mA	Resume on: CAN
Unit in "Wait for Event"		8		mA	Resume on: RS232
Unit in "Wait for Event", GSM On		15		mA	Resume on: GSM
<i>Typical measurements @ 12 VDC Supply.</i>					
Digital inputs	Min	Typ	Max		
	Logic "High"	8	12	40	VDC
Logic "Low"	-5	-	3	VDC	
Digital outputs (Solid state)	Min		Max		
	-	-	36	VDC	Protected against: Short circuit, ESD and inductive (Relay) kickback up to 20mH.
-	-	1.5	A		
Analog inputs	Min		Max		
	0	-	+10	VDC	Resolution is 10 bits. All inputs are protected against transients and low-pass filtered.
Storage temperature:	-30	-	+65	°C	<b>External interfaces:</b> <ul style="list-style-type: none"> <li>• TYCO "Mate'n'Lock" connector for: <ul style="list-style-type: none"> <li>▪ RS232 port 1 (service port)</li> <li>▪ Power, Digital I/O, Analog Input</li> <li>▪ CAN, RS485</li> </ul> </li> <li>• RJ45 for RS232 port 2 (EIA-561 compliant)</li> <li>• Three bi-color LED and one yellow status LED</li> <li>• Two DIP-Switches</li> <li>• SMA-Female connector for GSM antenna</li> <li>• SMB-Male for active 3 Volt GPS antenna</li> <li>• Standard 3 Volt SIM-Card reader (external access)</li> <li>• Nokia compatible Micro-Jack headset connector</li> </ul> All interfaces are externally accessible
Operating temperature <small>(According to GSM 11.10 specification)</small>	-25	-	+55	°C	
Restricted operation <small>(deviations from the GSM specification may occur)</small>	-30	-	+65	°C	
Charging Temperature	-10	-	+45	°C	
Humidity <small>(non condensing)</small>	5	-	90	%	
Weight	0.300			Kg	
External dimensions	W 97 x H 35 x D 132 mm			without SMA and SMB connectors	
Ingress Protection (IP)	IP30 (SIM/SD/Connectors in use)			Aluminum enclosure with	
Approvals	EN-61000-6-3;2001 Emission EN-61000-6-2;2001 Immunity			 10R-024899  034899 	

Technical data subject to change

## Specifications for the 66-channels SuperGPS receiver

### MediaTek MT3329 Single Chip SuperGPS

General:	66 Channels simultaneous operation A-GPS capable L1 frequency (1575.42MHz), C/A code Continuous tracking receiver	
Update Rate:	NMEA @ 1 Hz	
Accuracy:	Position	<2.5m CEP
	DGPS/SBAS	<2.5m CEP <sup>4</sup>
Sensitivity:	Tracking/navigation	-165 dBm
	Reacquisition	-160 dBm
	Cold Start (Autonomous)	-148 dBm
	<i>(GPS chipset reference parameters)</i>	
Time-To-First-Fix: <sup>5</sup>	Autonomous Operation in Standard Sensitivity Mode	
	Reacquisition	< 1 sec.
	Hot Start	< 1 sec.
	Aided start	< 3 sec.
	Warm start	32 sec.
	Cold start	32 sec.
Interface protocol:	NMEA 0183 v3.0 with GGA, VTG, GLL, GSA, GSV and RMC	

#### Definitions:

##### Reacquisition:

Time to get a fix when signal has been blocked for a short period of time.

##### Hot Start:

The GPS has been powered down for less than 2 hours and the stored position and time are valid

##### Aided Start:

The GPS has valid A-GPS information. A-GPS is currently unsupported in the standard firmware.

##### Warm Start:

The GPS has been powered down for more than one hour, but has stored information about its current position and time

##### Cold Start:

The GPS has no valid navigation data.

<sup>4</sup> Depends on accuracy of correction data provided by the SBAS service

<sup>5</sup> All satellites at -130 dBm

## Appendix A – Enabling the CAN bus Write capability

Connecting the RTCU to a CAN network can be dangerous. If the RTCU is not configured with the correct network parameters, it can lead to network corruption and may interfere with other connected equipment on the bus. Especially in vehicles great precautions must be observed to prevent interruption of the communication.

By default reading from the CAN bus is enabled and writing to the CAN bus is disabled by a hardware jumper inside the unit.

***Installing this jumper, and thereby enabling the CAN-bus Write capability of the unit, is done on the sole responsibility of the user. Logic IO can not be held responsible for any problems, or damage due to the decision to enable the CAN-bus Write capability.***

The following steps must be taken to enable the CAN bus Write capability of the unit:

1. Remove the back endplate – the one where the four Tyco connectors are located. Use a screwdriver (PH1) to remove the two screws.



2. Gently pull out the electronic board approximately.  
Hint: Use a finger to push on the RJ45 connector on the opposite endplate.

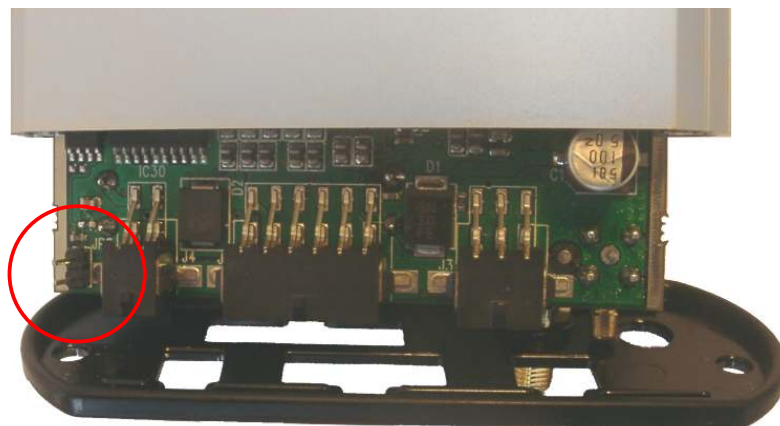

3. Mount the jumper, as shown on the picture below:

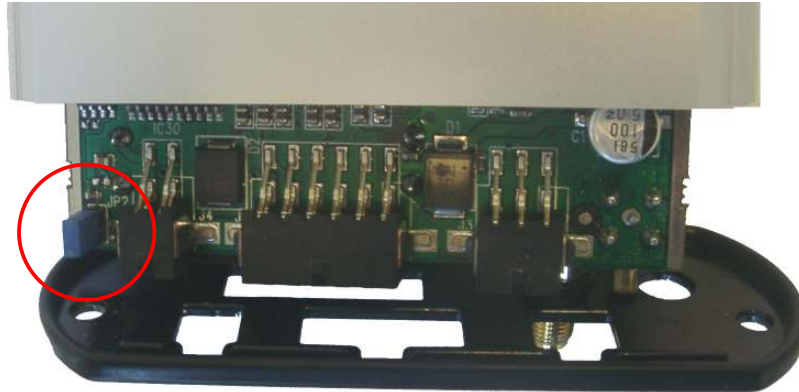

4. Gently push the electronic board back into the encapsulation again. In any case DO NOT USE FORCE. If difficulty is experienced it is because the light-pipes on the opposite endplate has moved a bit when the electronic board was removed and it might be necessary to loosen the front endplate a bit to make them fit in the holes again.
5. Mount the endplate and secure it with the screws. Be careful not to tighten the screws too much and thereby damaging the threads.

